

Design Considerations for a Small Space Telescope

Don Platt

1. Introduction

I present a preliminary design for a small space telescope. Included in this report will be optical bench, sensor, and attitude control and pointing system design considerations.

This project is to be submitted as a proposal for a small satellite mission to be considered to fly as a hitch-hiker payload on a Boeing Inertial Upper Stage (IUS) communications satellite deployment mission. Due to having to design for a spacecraft envelope size of 30 cm x 30 cm x 60 cm the primary mirror is limited in size to 10 inches (25.4 cm).

With recent advances in Charge Coupled Device (CCD) image systems it is now possible to build a space telescope with wavelength sensitivity from 200 nm to 1000 nm. The near-ultraviolet region to be studied by this system (200 - ~ 400 nm) is of special interest because this wavelength region is largely absorbed by the atmosphere and is therefore not visible from the ground. A folded optics Cassegrain system is the telescope system design of choice due to the limited space available.

Also studied is the possibility of combining two satellites into an optical interferometry system. With the advances in computers, sensors and communications systems light from two telescopes might be combined into an optical interferometer. This would increase the apparent aperture size of the system. This cheap, small system could be a good test-bed for such unproven technology.

The observatory could be open to a guest observer program similar to several other space-based astronomical observatories. Proposals for observing time could be accepted from anyone with a scientifically useful observing plan from professionals and amateurs alike. Perhaps real-time imaging could be displayed over the World Wide Web to subscribers.

2. Optics System

Due to the size limitations of the design requirements for this mission a small mirror of 10 inches (25.4 cm) is the maximum aperture available. However, with advances in modern astronomical detectors it is possible to do useful research with such a small mirror (Astronomy, Dec. 1996).

A Cassegrain folded optics system is the telescope design of choice for this satellite. For volume considerations an extendable section will hold the secondary mirror which will then be deployed upon orbit (see Figure 1). A telescope of this type has a typical focal ratio of 5 with mirrors made of fused silica with a lithium fluoride-aluminum coating (Thompson and Shannon, 1974).

The focal length of a Cassegrain telescope can then be found from:

$$F=FR*D$$

where F is the focal length, FR equals the focal ratio and D equals the diameter of the primary mirror. Using this equation we get a focal length, F equal to 1.27 meters. The focal lengths of the

primary and secondary mirrors can then be selected to fit within the space available on the satellite from the following equation where f_1 is the focal length of the primary and f_2 is the focal length of the secondary, which is negative for a hyperbolic secondary and d is the distance between the two mirrors (Walker,1987).

$$1/f = 1/f_1 + 1/f_2 - d/f_1f_2$$

The Raleigh Diffraction criteria, θ , defines the smallest angle two closely spaced images like two stars can be and still just be seen as two separate images. This can be found from the following equation where λ is the peak wavelength, assumed to be 550 nm and D is the telescope primary mirror diameter:

$$\theta = 1.22 \lambda/D$$

From this equation θ is found to be 5.44×10^{-4} arc seconds. Taking advantage of being above atmospheric turbulence this resolution limit should be possible with high quality optics with this telescope system.

3. Sensors

A charge-coupled device (CCD) is the imaging device to be used on this system. A CCD is a solid-state device made from silicon. In crystalline silicon, each atom is covalently bonded to its neighbors. Incident photons of wavelength shorter than 1100 nm can break the bonds and generate electron-hole pairs. The rate of electron-hole pair generation due to thermal energy (dark current) is very dependent on temperature and can be reduced through cooling the system.

When a CCD imager is exposed to light, charge accumulates in the potential wells of parallel registers. Over time a charge can accumulate with the total charge proportional to the intensity of light and exposure time. The serial register then receives the charge packets from the parallel register and the output is sent to an output amplifier. After the serial registers are emptied the next row of charge packets are shifted over in what is called a bucket-brigade.

Quantum efficiency measures a sensor's efficiency in generating electronic charge from incident photons. Electron hole pairs are produced by photons in the region from 400 to 1100 nm. The creation of charge is linear to the light the CCD receives so this allows easy manipulation and processing of multiple exposures with a computer.

Light normally enters the CCD through the gates of the parallel register. These gates are made from very thin polysilicon which is essentially transparent at visible wavelengths but becomes opaque at wavelengths shorter than 400 nm. Light shorter than this wavelength is attenuated by the gate structure when it passes through the frontside of a CCD in what is known as a frontside illuminated CCD. It is possible to create an extremely thin CCD which is about 20 microns thick and then to focus light on the backside of the device. There are no polysilicon gates to absorb light in this system so a back thinned CCD exhibits a quantum efficiency of up to 80 % (see Figure 2).

Recent advances in CCD technology has improved the CCD's response to near ultraviolet light.

The sensitivity in this wavelength region can be improved using an organic coating called Metachrome. This coating absorbs light between 80 and 400 nm and re-emits it in the visible region of the spectrum. Metachrome is completely transparent to wavelengths longer than 400 nm so the quantum efficiency of the system is not compromised. Other UV coatings reduce the visible light response of the system but since Metachrome is an organic converter it does not exhibit this problem.

Photometrics has developed a METACHROME II phosphor coating that when applied in a 0.4 to 0.6 nm thick film to a frontside-illuminated CCD will greatly improve the quantum efficiency in the 120 to 430 nm range. Photometrics has conducted extensive testing of METACHROME II at both -45C and -100C with no cracking or delamination of coatings. When a METACHROME II coated CCD is operated in a vacuum and cooled to at least -40C, no detrimental effects from exposure to intense ultraviolet or visible light are observed (Photometrics WWW site).

Taking advantage of the developments in the field of improving the UV response of CCDs, I would select as a first choice for a UV/Visible imaging telescope detector a back illuminated CCD with 16 bits per pixel, giving 65,535 gray levels. As an alternative a front-illuminated CCD with a METACHROME II coating could be used with a slight loss in UV sensitivity (Figure 3). A spectrograph and filter wheel could also be placed in the light path to greatly increase the scientific value of the telescope's observations.

4. Attitude Control / Pointing

In order to not use a complex thruster system, a zero-momentum reaction control system is selected. In this type of system, a vehicle pointing error produces a signal which speeds up a reaction wheel. This torque corrects the vehicle and leaves the wheel spinning at low speed, until another pointing error makes the wheel either spin faster or slow down. A magnetic torquer would then be used when the wheel reaches saturation (Larson and Wertz, pg. 348).

A reaction wheel is a torque motor with high-inertia motors. These wheels can spin in either direction, and provide one axis of control for each wheel. For this reason, three wheels are necessary for three-axis control. The actuators are magnetic torquers which are magnetic coils or electromagnets to generate magnetic dipole moments. This torquer system produces torque proportional and perpendicular to the Earth's magnetic field. A magnetometer is also needed for magnetic field sensing. An Inertial Measurement Unit consisting of gyroscopes to determine the spacecraft's attitude. The Litton G2000 gyro offers a two-axis gyro with a size of only 0.97 inches tall by 0.76 inches wide and weighs 25 grams. This small size is perfect for this application. This gyro system can be combined with a star sensor system to provide attitude position information. Combined this Attitude Control System should provide a pointing accuracy of 0.1 degree.

5. Optical Interferometry

An astronomical interferometer combines the light gathering of two or more telescopes separated by a baseline distance. This type of instrument can achieve the resolution of a telescope with an aperture equal to the baseline. The interferometer preserves the phase relationships between beams from different telescopes. The optical train of the interferometer must be continually adjusted to equalize the optical path lengths from the star, through the telescopes and to the

detector. Interference fringes will appear if the path lengths are equal to within a few wavelengths. The amplitudes and phases of the fringes are measured and related through a Fourier transform to the distribution of brightness across the sky.

An optical interferometer is much more difficult than a radio interferometry system for two reasons. First, a low-noise, phase coherent amplifier is readily available at radio wavelengths but has yet to be built at optical wavelengths. Secondly, atmospheric turbulence is much less of a factor at radio wavelengths than at optical wavelengths.

A space-based interferometer would then not have to deal with the problem of atmospheric turbulence. It is for this reason that it may be profitable to look at developing a space-based optical interferometer. Also, space could provide a large baseline being the separation of two spacecraft on opposite sides of the Earth in orbit.

The two key elements of the interferometer are the system that equalizes the path lengths taken by the light waves collected by the separate telescopes and the system that correlates the waves once they have been brought together. The resulting data of fringe amplitudes, phases and positions are used to produce the image (Armstrong, et.al, 1995). It is also possible that today's advanced computing power could be used to re-construct the fringes in an interferometer. A high-speed computer system could be used to produce these images.

6. Possible Uses

Small space-instruments are essential for scanning large areas of the sky, for discovering and cataloging new objects, and for monitoring variable or transient sources of radiation (Dyson, 1990). With this telescope being above the atmosphere its images should be virtually diffraction limited, offering excellent image quality and research potential. Professional observatories are currently vastly over booked for observing time so a series of these cheap small space telescopes could be used to do many observing projects that currently require large ground-based telescopes.

This system could be used for long-period observing programs that currently can't be done with large earth-based systems due to limited observing time. The type of projects that the small space telescope could tackle include observations of variable stars over extended time frames, observations of binary stars, ultra-violet photometry and spectroscopy not possible on the earth and extra-galactic supernova.

Observations could be planned and controlled over the internet similar to robotic observatories currently being used by the Bradford Robotic Telescope project at Yorkshire, England (Sky & Telescope, December, 1996). Users could register and then be allowed to use the system after paying an observation fee.

7. Conclusion

Flying above the atmosphere, even a small space telescope can produce valuable research. By using commercially available components, whenever possible, cost of the system can be kept down. Several satellites could be placed in orbit for redundancy, multiple observations and possibly to develop an optical interferometer system. Observing time can be made available to both professional and amateur groups and access can be offered through internet to subscribers

and registered users.

With new advances in CCD technology, the telescope can use an inexpensive CCD detector with its linear response and computer capabilities to observe from the near ultraviolet to the near infrared. By placing a spectrograph on board the satellite an even more capable system can be developed.

8. References

Armstrong, J.T., D.J. Hunter, K.J. Johnston, and D. Mozurkewich. 1995. Stellar Optical Interferometry in the 90's, *Physics Today*, May: 42-49.

Baruch, J.E.F. 1996. Ready for Robotic Astronomy?, *December*: 92-94.

Kondo, Y., ed. 1990. *Observatories in Earth Orbit and Beyond*. The Netherlands: Kluwer Academic Publishers.

Larson, Wiley J. and Wertz, James R., eds. 1992. *Space Mission Analysis and Design*. Torrance, CA: Microcosm, Inc.

Stern, S.A. 1996. Wish Upon a Star, *Astronomy*, December: 48-51.

Thompson, B.J. and R.R. Shannon, eds. 1974. *Space Optics-Proceedings of the Ninth International Congress of the International Commission for Optics*. Washington, D.C.:National Academy of Sciences.

Walker, Gordon. 1987. *Astronomical Observations*. Cambridge: Cambridge University Press.

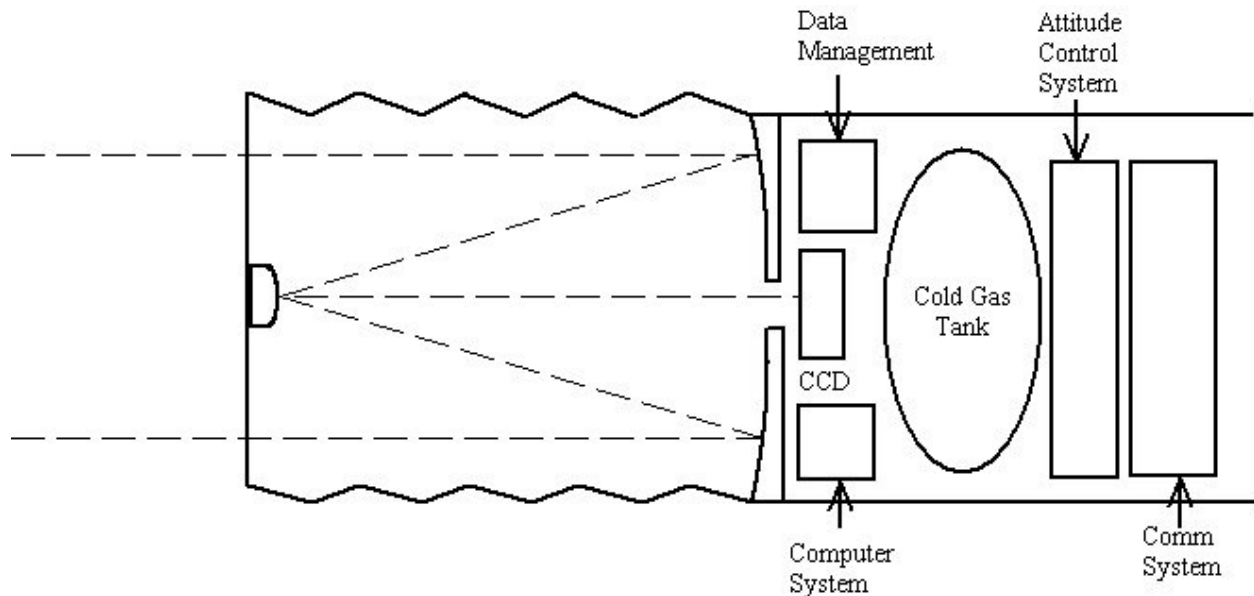

Figure 1 Telescope Optical and subsystem layout

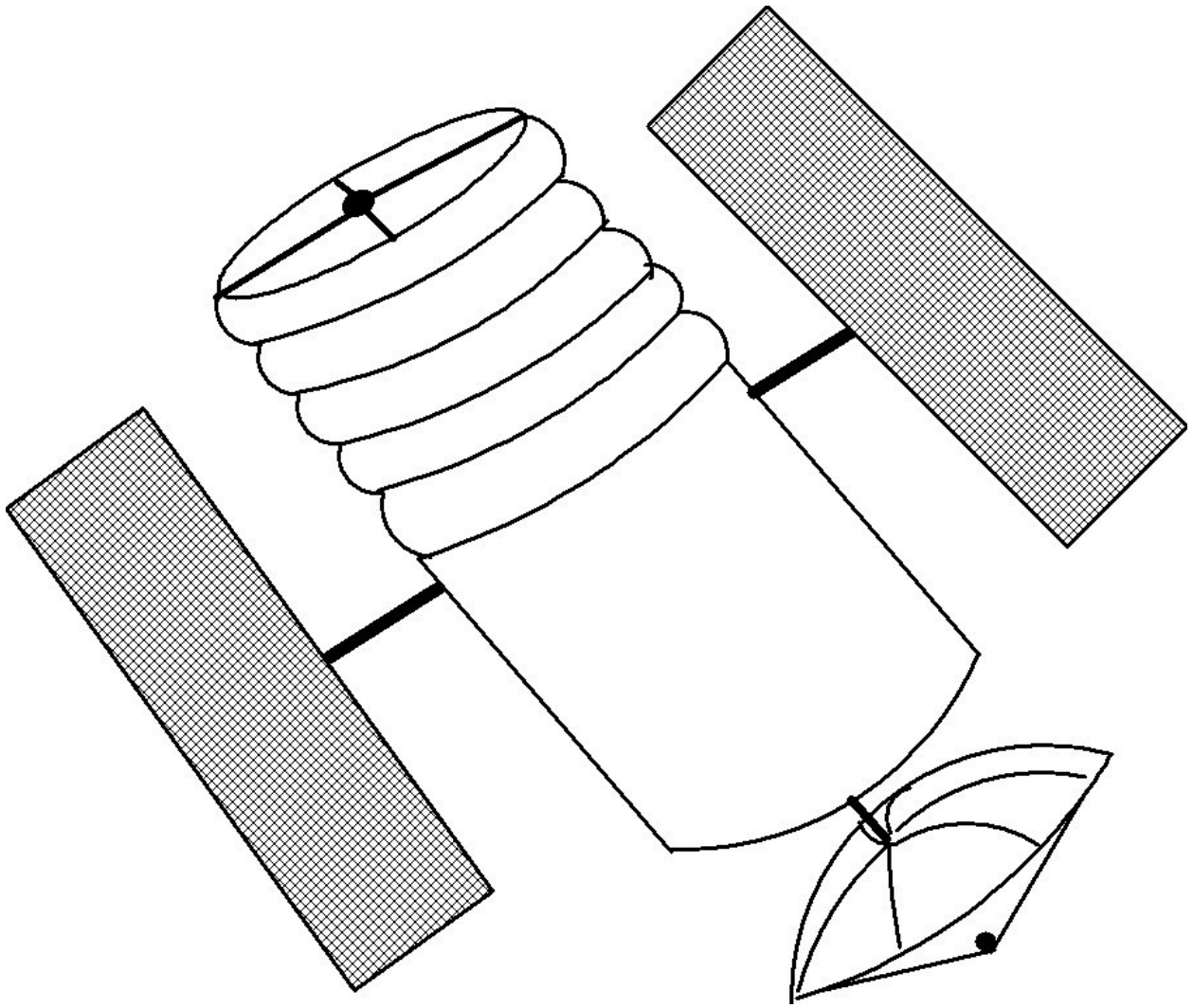

Figure 2 A Possible Configuration for a Small Space Telescope

Subsystem	Mass (Kg)
Structure	4.3
Comm	10
Optics	10
Thermal Control	2
Power	15
ADCS	15
Propulsion	30
Margin	5
Total	92

Table 1 Spacecraft Mass Budget